

- CONTENTS -

1. Features
2. Outline dimensions
3. Absolute Maximum Ratings
4. Electrical Optical Characteristics
5. Ranks
6. Packing
7. Characteristic Diagrams
8. Reliability
9. Cautions
10. Warranty
11. Others
12. Revision history sheet

1. Features

- Colorless transparency lens type
- $\phi 5\text{mm}$ (T-1 $\frac{3}{4}$) all plastic mold type
- High Luminosity
- ESD Class(Mil Std-883d Method 3015.7) based on Human Body Model(HBM) : Class 1

2. Outline dimensions

(unit : mm)

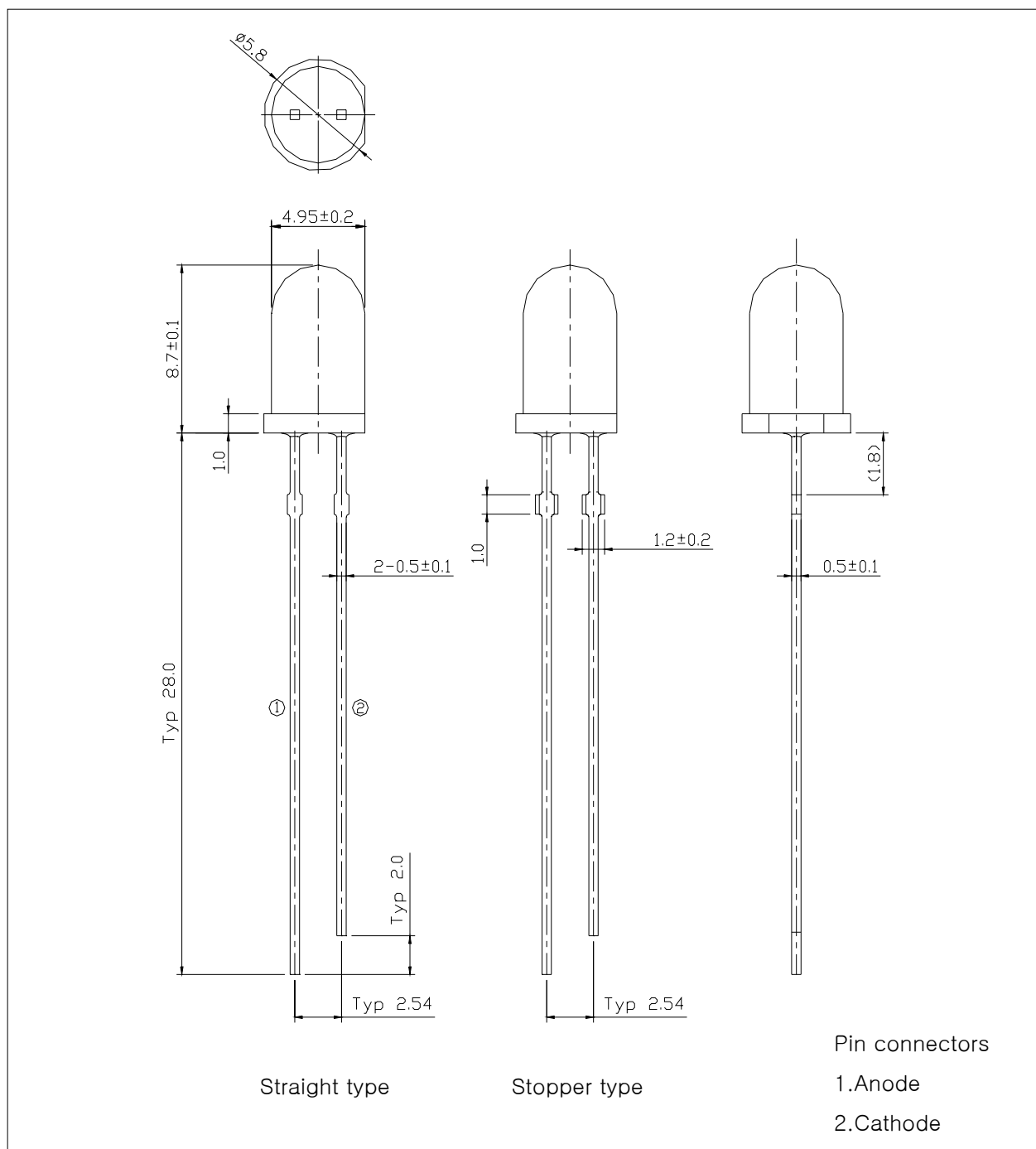

3. Absolute Maximum Ratings

(Ta=25°C)

Characteristic	Symbol	Ratings	Unit
Power dissipation	P_D	75	mW
Forward Current	I_F	30	mA
* ¹ Peak Forward Current	I_{FP}	100	mA
Reverse Voltage	V_R	5	V
Operating Temperature	T_{opr}	-30 ~ +85	°C
Storage Temperature	T_{stg}	-40 ~ +100	°C
* ² Soldering Temperature	T_{sol}	260°C for 10 seconds	

*¹.Duty ratio 1/10, Pulse Width 10msec

*².Keep the distance more than 2.0mm from PCB to the bottom of LED package

4. Electrical – Optical Characteristics

(Ta=25°C)

Characteristic	Symbol	Test Condition	Min.	Typ.	Max.	Unit
* ³ Forward Voltage	V_F	$I_F=20mA$	-	2.0	2.6	V
Dominant Wavelength	λ_d	$I_F=20mA$	-	645	-	nm
Spectrum Bandwidth	$\Delta\lambda$	$I_F=20mA$	-	20	-	nm
Reverse Current	I_R	$V_R=5V$	-	-	10	uA
* ⁴ Half Angle	$\theta_{1/2}$	$I_F=20mA$	-	±20	-	deg

*³. Voltages are tested at a current pulse duration of 1 ms and an accuracy of ±0.1V

*⁴. $\theta_{1/2}$ is the off-axis angle where the luminous intensity is 1/2 the peak intensity

5. Ranks

(1) Luminous intensity ranks

(Ta=25°C)

Iv RANK	Test Condition	Min.	Typ.	Max.	Unit
M	I _F = 20mA	420	–	600	mcd
N		600	–	850	
O		850	–	1200	

* Luminous intensity is tested at a current pulse duration of 25 ms and an accuracy of $\pm 11\%$.

* Luminous Intensity Measured : 0.01sr(CIE. LED_B)

(2) Precautions On LED using

* To avoid optical difference, Please do not mix differently-ranked product.

6. Packing

(1) Label Outline



* SIZE(L X W) : 40mm X 23mm

lv Rank(ex. N, O)

(2) Lot Number

The first six digits number shows lot number

The lot number is composed of the following characters:

○□◇△■●-xxx

- - Luxpia Initial (L for Luxpia)
- - Chip maker (A for Chip Maker)
- ◇ - Year (04 for 2004, 05 for 2005)
- △ - Month (A for Jan., B for Feb.)
- - Day (01 for 01., 12 for 12.)
- - Product input No. (A for first, B for second.)
- xxx - Luxpia's Product Number

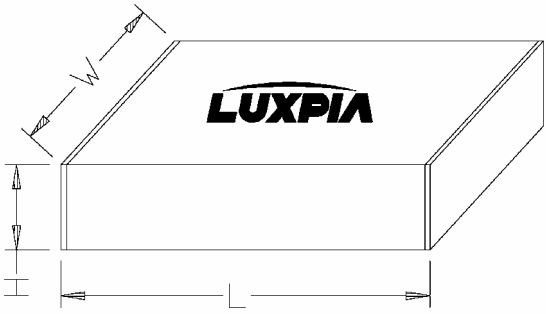
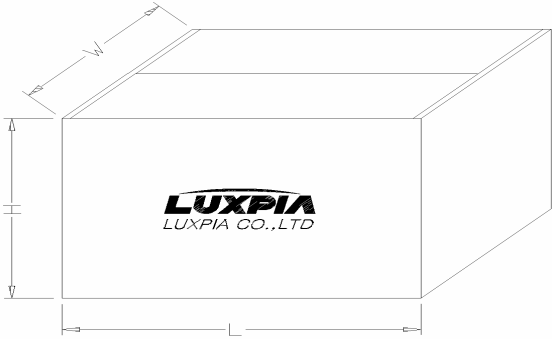
구분	Outline Dimension(mm)	구성
Inner Box		<ul style="list-style-type: none"> - 250pcs / Bulk Bag (Bulk bag = Shield bag) - Bulk 8ea/Inner box(2,000pcs) - L X W X H = 240 X 167 X 66mm
Out Box		<ul style="list-style-type: none"> - Inner 10 box/out box(20,000pcs) - L X W X H = 359 X 369 X 262mm

- The LEDs are packed in cardboard boxes after the LEDs are sealed in shield bags.
The label on the minimum packing unit shows : Part Number, Lot Number, Ranking, Quantity
- In order to protect the LEDs from mechanical shock, we pack them in cardboard boxes for transportation.
- The LEDs may be damaged if the boxes are dropped or receive a strong impact against them, so precautions must be taken to prevent any damage.
- The boxes are not water resistant and therefore must be kept away from water and moisture.
- When the LEDs are transported, we recommend that you use the same packing method as Luxpia.
- If a box shows noticeable damage upon arrival at the User's warehouse. It is recommended that the User submit a claim to Luxpia within one weeks after arrival of the products. If the submitted notice regarding the damage exceeds the aforementioned two weeks, it will be treated in the manner shown in term 11.

7. Characteristic Diagrams

Fig.1 I_F - V_F

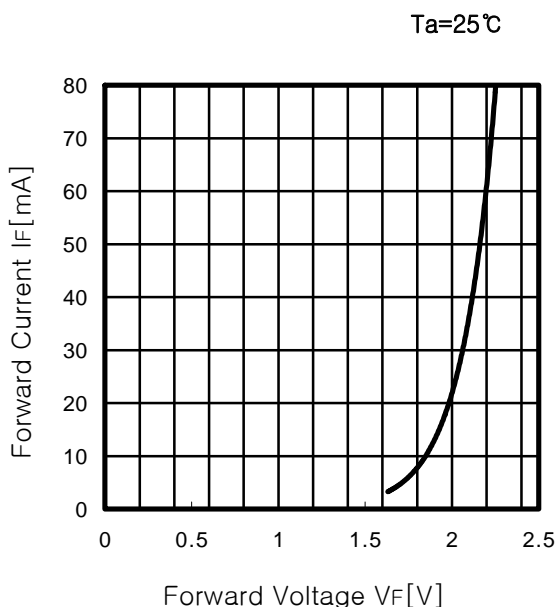

Fig.2 I_v - I_F

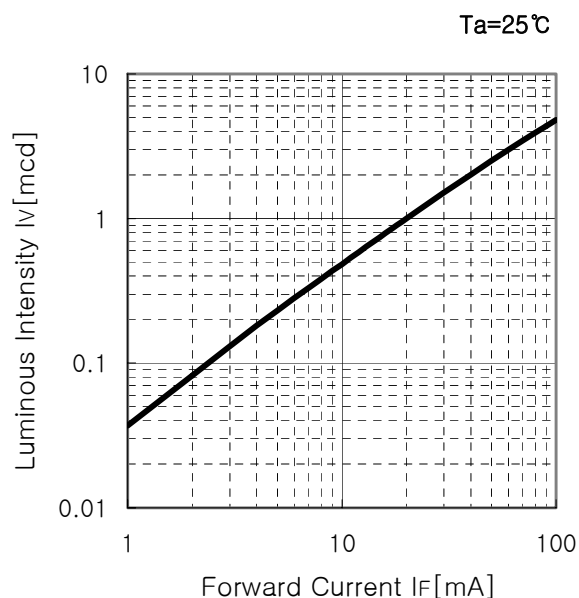

Fig.3 Max. Permissible Forward Current

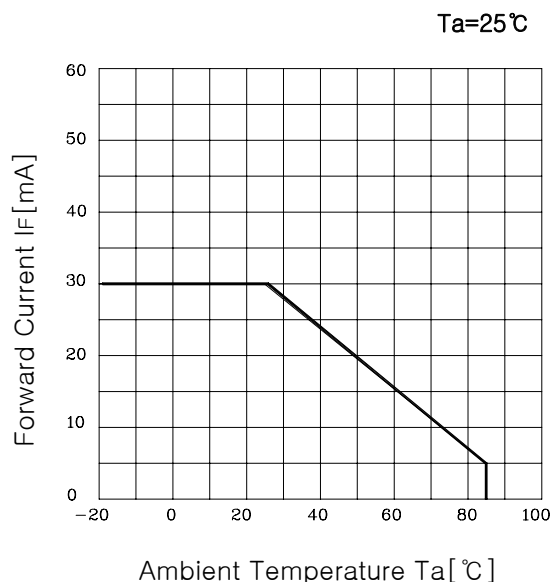

Fig.4 Spectrum Distribution

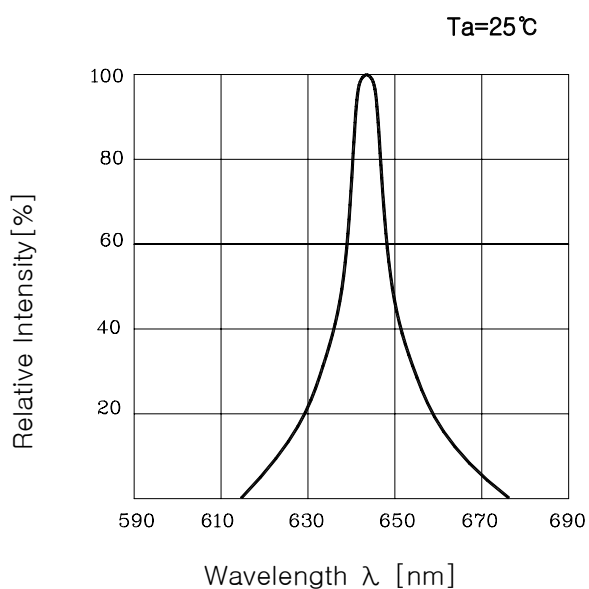

Fig. 5 Relative Intensity-Ta

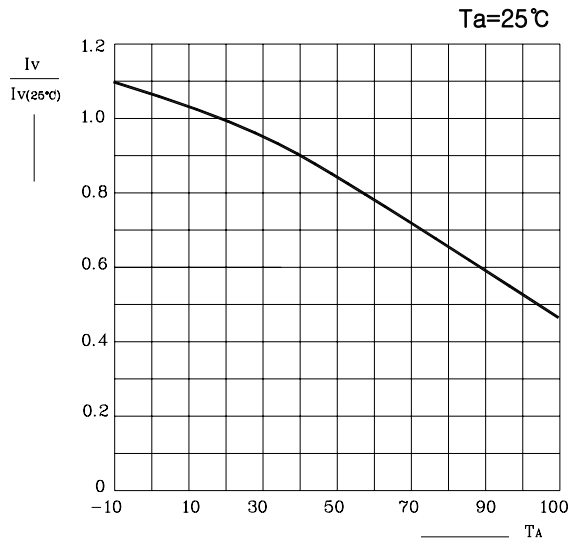
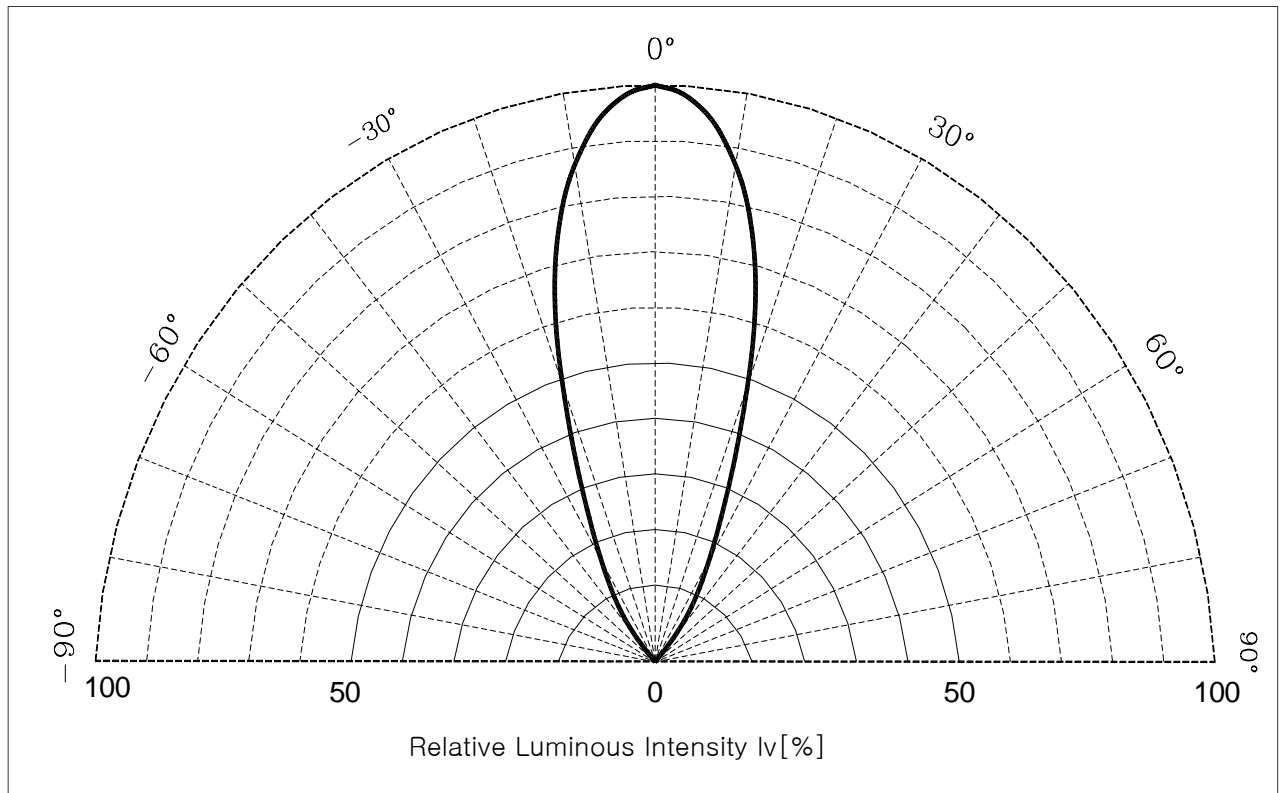

Fig. 6 Radiation Diagram



8. Reliability

(1) The Reliability criteria of Lamp LED

ITEM	Symbol	Test Condition	Limit	
			Min.	Max.
Forward Voltage	V _F	I _F = 20mA	I.V × 0.9	I.V × 1.1
Reverse Current	I _R	V _R = 5V	-	1.5
Luminous intensity	I _v	I _F = 20mA	I.V × 0.7	I.V × 1.3
Chromaticity Coordinates	x, y	I _F = 20mA	I.V × 0.8	I.V × 1.2

* I.V : Initial Value U : Upper Spec Limit L : Lower Spec Limit

(2) Results of reliability Test

NO	Item	Test Conditions	Time	Ac/Re (검토, 보증)
1	Steady State Operating Life	T _a =25℃, I _f =30mA	1000hrs	0/22, 0/45
2	Steady State Operating Life of Low Temperature	T _a =-30℃, I _f =20mA	1000hrs	0/22, 0/45
3	Steady State Operating Life of High Temperature	T _a =85℃, I _f =5mA	1000hrs	0/22, 0/45
4	Steady State Operating Life of High Humidity Heat	T _a =60℃, RH=90%, I _f =15mA	1000hrs	0/22, 0/45
5	Temperature Cycle	T _a =-40℃~25℃~100℃~25℃ Time=30min~5min~30min~5min	100Cycle	0/22, 0/45
6	Low Temperature Storage	T _a =-40℃	1000hrs	0/22, 0/45
7	High Temperature Storage	T _a =100℃	1000hrs	0/22, 0/45
8	Temperature Humidity Storage	T _a =60℃, RH=90%	1000hrs	0/22, 0/45
9	SHT(Reflow)	T _{sld} =260℃, 10sec	1 time	0/22, 0/45

9. Cautions

(1)Lead Forming

- When forming leads, the leads should be bent at a point at least 3mm from the base of the epoxy bulb.
Do not use the base of the leadframe as a fulcrum during lead forming.
- Lead forming must be done before soldering.
- Do not apply any bending stress to the base of the lead.
The stress to the base may damage the LED's characteristics or it may break the LEDs.
- When mounting the LEDs onto a printed circuit board, the holes on the circuit board should be exactly aligned with the leads of the LEDs. If the LEDs are mounted with stress at the lead, it cause deterioration of the epoxy resin and this will degrade the LEDs.

(2)Storage

- The LEDs should be kept at 30°C or less and 70%RH or less. The LEDs should be used within 3 months. When storing the LEDs, moisture proof packaging with absorbent material (silica gel) is recommended.
- Luxpia LED electrode sections are comprised of a silver plated copper alloy. The silver surface may be affected by environments which contain corrosive gases and so on. Please avoid condition may cause difficulty during soldering operations. It is recommended that the User use the LEDs as soon as possible.
- Please avoid rapid transitions in ambient temperature, especially in high humidity environments where condensation can occur.

(3)Static Electricity

- Static electricity or surge voltage damages the LEDs.
It is recommended that a wrist band or an anti-electrostatic glove be used when handling the LEDs.
- All devices, equipment and machinery must be properly grounded.
It is recommended that measures be taken against surge voltage to the equipment that mounts the LEDs.
- When inspecting the final products in which LEDs were assembled, it is recommended to check whether the assembled LEDs are damaged by static electricity or not. It is easy to find static-damaged LEDs by a light-on test or a VF test at a lower current (below 1mA is recommended).
- Damaged LEDs will show some unusual characteristics such as the leak current remarkably increases, the forward voltage becomes lower, or the LEDs do not light at the low current.

Criteria : (VF > 2.0V at IF=0.5mA)

(4) Soldering Conditions

- The LED leadframes are comprised of a silver plated Iron alloy. This substance has a low thermal coefficient. Careful attention should be paid during soldering
- Solder the LED no closer than 3mm from the base of the epoxy bulb.
- Recommended soldering conditions

Dip Soldering		Hand Soldering	
Pre-heat	120°C Max	Temperature	350°C Max
Pre-heat time	60 sec Max	Soldering time	3sec Max
Peak temperature	260°C Max	position	(one time only)
Dipping time	10sec Max		No closer than 3mm
Dipping position	No closer than 3mm From the base of the Epoxy bulb.		From the base of the Epoxy bulb.

- When soldering, do not put stress on the LEDs during heating.
- The LEDs must not be repositioned after soldering.
- After soldering the LEDs, the epoxy bulb should be protected from mechanical shock or vibration until the LEDs return to room temperature.
- Direct soldering onto a PC board should be avoided. Mechanical stress to the resin may be caused from warping of the PC board or from the clinching and cutting of the leadframes. When it is absolutely necessary, the LEDs may be mounted in this fashion but the User will Assume responsibility for any problems.
- When it is necessary to clamp the LEDs to prevent soldering failure, it is important to minimize the mechanical stress on the LEDs.
- Cut the LEDs leadframes at room temperature. Cutting the leadframes at high temperatures may cause failure of the LEDs.

(5) Cleaning

- It is recommended that isopropyl alcohol be used as a solvent for cleaning the LEDs. When using other solvents, it should be confirmed beforehand whether the solvents will dissolve the package and the resin or not. Freon solvents should not be used to clean the LEDs because of worldwide regulations. Do not clean the LEDs by the ultrasonic. When it is absolutely necessary, the influence of ultrasonic cleaning on the LEDs depends on factors such as ultrasonic power and the assembled condition.
Before cleaning, a pre-test should be done to confirm whether any damage to the LEDs will occur.

(6) Others

- Care must be taken to ensure that the reverse voltage will not exceed the absolute maximum rating when using the LEDs with matrix drive.
- These LEDs are designed and manufactured for standard applications of traffic signals. It is recommended to consult with Luxpia in advance if these LEDs are used for other applications.
- The LED light output is strong enough to injure human eyes. Precautions must be taken to prevent looking directly at the LEDs with unaided eyes for more than a few seconds.
- Flashing lights have been known to cause discomfort in people; you can prevent this by taking precautions during use. Also, people should be cautious when using equipment that has had LEDs incorporated into it.

10. Warranty

- (1) Luxpia warrants that its LEDs conform to the foregoing specifications and that Luxpia will convey good title to all LEDs sold.
- (2) Luxpia Disclaims all other warranties including the implied warranties of merchantability and fitness for a particular purpose.
- (3) In the event any LED supplied by Luxpia is found not to conform to the foregoing specifications within ninety days of receipt, Luxpia will repair or replace the LED, at Luxpia's discretion, provided that the User (1) promptly notifies Luxpia in writing of the details of the defect (2) ships the LEDs at the User's expense to Luxpia for examination, and (3) the defect is due to the negligence of Luxpia and not mishandling or misuse by the User.
- (4) Luxpia will not take responsibility for any trouble that is caused by using the LEDs at conditions exceeding our specifications.
- (5) These specifications are applied only when a LED stands alone and it is strongly recommended that the User of the LEDs confirms the properties upon assembly. Luxpia is not responsible for failures caused during and after assembling.
It will be excepted from the rule if the failure would caused undoubtedly by Luxpia.
- (6) A claim report stating details about the defect shall be made when returning defective LEDs. Luxpia will investigate the report immediately and inform the user of the results.
- (7) The LEDs described in this brochure are intended to be used for ordinary electronic equipment (Such as office equipment, communications equipment, on the applications in which exceptional quality and reliability are required, particularly when the failure or malfunction of the LEDs may directly jeopardize life or health (such as for airplanes, aerospace, submersible repeaters, nuclear reactor control systems, automobiles, traffic control equipment, life support systems and safety devices)
- (8) Luxpia's liability for defective lamps shall be limited to replacement and in no event shall Luxpia be liable for consequential damage or lost profits.

11. Others

- (1) The warranties of quality set forth herein are exclusive. All previous negotiations and agreements not specifically incorporated herein are superseded and rendered null and void.
- (2) Both parties shall sincerely try to find a solution when any disagreement occurs regarding these specifications.
- (3) User shall not reverse engineer by disassembling or analysis of the LEDs without having prior written consent from Luxpia. When defective LEDs are found, the User shall inform Luxpia directly before disassembling or analysis.
- (4) These specifications can be revised upon mutual agreement.
- (5) Luxpia understands that the User accepts the content of these specifications, if the User does not return these specifications with signatures within 3 weeks after receipt

12. Revision history sheet

Spec NO.			
Title	Specification for Approval		
Times	Date	Summary of revision	Remarks
1	2001. 07. 15	신규제정	
2	2003. 02. 26	Format 변경	
3	2003. 08. 06	VF Rank 세분화	
4.	2004. 10. 25	Format 변경	